

BIT SET • S2 STEEL

H4x28mm BITS

- ⊕ PH0000 • PH000 • PH00 • PH0
- ⊕ PH1 • PH2
- 1.0 • 1.5 • 2.5 • 3.0 • 4.0
- ⊕ Y0.6 • Y1.5 • Y2.5 • Y3.0
- ⊕ T1 • T2 • T3 • T4
- ⊕ T5H • T6H • T7H • T8H • T9H • T10H • T15H • T20H
- H0.7 • H0.9 • H1.3 • H1.5 • H2.0 • H2.5 • H3.0 • H3.5 • H4.0
- SQ0 • SQ1 • SQ2
- ⊕ P2(0.8) • P5(1.2) • P6(1.5)
- ⊕ P2(0.8) • P5(1.2) • P6(1.5)
- ▲ 2.0 • 2.3
- U2.0 ⊕ MID ● SIM

H4x45mm BITS

- ⊕ PH0 • PH1 • PH2
- ⊖ 2.0 • 3.0
- ⊕ T6H • T8H • T9H • T10H • T15H • T20H
- H1.5 • H2.0 • H2.5
- ▲ 3.0
- U2.6

- Elektrický skrutkovač
- Magnetizer / Demagnetizer



BIT SET • S2 STEEL

H4x28mm BITS

- ⊕ PH0000 • PH000 • PH00 • PH0
- ⊕ PH1 • PH2
- 1.0 • 1.5 • 2.5 • 3.0 • 4.0
- ⊕ Y0.6 • Y1.5 • Y2.5 • Y3.0
- ⊕ T1 • T2 • T3 • T4
- ⊕ T5H • T6H • T7H • T8H • T9H • T10H • T15H • T20H
- H0.7 • H0.9 • H1.3 • H1.5 • H2.0 • H2.5 • H3.0 • H3.5 • H4.0
- SQ0 • SQ1 • SQ2
- ⊕ P2(0.8) • P5(1.2) • P6(1.5)
- ⊕ P2(0.8) • P5(1.2) • P6(1.5)
- ▲ 2.0 • 2.3
- U2.0 ⊕ MID ● SIM

H4x45mm BITS

- ⊕ PH0 • PH1 • PH2
- ⊖ 2.0 • 3.0
- ⊕ T6H • T8H • T9H • T10H • T15H • T20H
- H1.5 • H2.0 • H2.5
- ▲ 3.0
- U2.6

- Elektrický šroubovák
- Magnetizer / Demagnetizer



BIT SET • S2 STEEL

H4x28mm BITS

- ⊕ PH0000 • PH000 • PH00 • PH0
- ⊕ PH1 • PH2
- 1.0 • 1.5 • 2.5 • 3.0 • 4.0
- ⊕ Y0.6 • Y1.5 • Y2.5 • Y3.0
- ⊕ T1 • T2 • T3 • T4
- ⊕ T5H • T6H • T7H • T8H • T9H • T10H • T15H • T20H
- H0.7 • H0.9 • H1.3 • H1.5 • H2.0 • H2.5 • H3.0 • H3.5 • H4.0
- SQ0 • SQ1 • SQ2
- ⊕ P2(0.8) • P5(1.2) • P6(1.5)
- ⊕ P2(0.8) • P5(1.2) • P6(1.5)
- ▲ 2.0 • 2.3
- U2.0 ⊕ MID ● SIM

H4x45mm BITS

- ⊕ PH0 • PH1 • PH2
- ⊖ 2.0 • 3.0
- ⊕ T6H • T8H • T9H • T10H • T15H • T20H
- H1.5 • H2.0 • H2.5
- ▲ 3.0
- U2.6

- Elektromos csavarhúzó
- Mágnesesítő / Demágnesesítő



BIT SET • S2 STEEL

H4x28mm BITS

- ⊕ PH0000 • PH000 • PH00 • PH0
- ⊕ PH1 • PH2
- 1.0 • 1.5 • 2.5 • 3.0 • 4.0
- ⊕ Y0.6 • Y1.5 • Y2.5 • Y3.0
- ⊕ T1 • T2 • T3 • T4
- ⊕ T5H • T6H • T7H • T8H • T9H • T10H • T15H • T20H
- H0.7 • H0.9 • H1.3 • H1.5 • H2.0 • H2.5 • H3.0 • H3.5 • H4.0
- SQ0 • SQ1 • SQ2
- ⊕ P2(0.8) • P5(1.2) • P6(1.5)
- ⊕ P2(0.8) • P5(1.2) • P6(1.5)
- ▲ 2.0 • 2.3
- U2.0 ⊕ MID ● SIM

H4x45mm BITS

- ⊕ PH0 • PH1 • PH2
- ⊖ 2.0 • 3.0
- ⊕ T6H • T8H • T9H • T10H • T15H • T20H
- H1.5 • H2.0 • H2.5
- ▲ 3.0
- U2.6

- Electric screwdriver
- Magnetizer / Demagnetizer



Parametre produktu

Rozmer: 16x16x180mm
Váha: 71g
Prevod: 2 prevody
Rýchlosť naprázdno: 200o/min
Krútiaci moment: 0.3Nm / 0.4Nm

Voltáž batérie : 3.7v
Lítiová batéria: 350mAh
Čas nabíjania: 60min
Pohotovostný režim: 60 dní
Pracovný čas : 120min

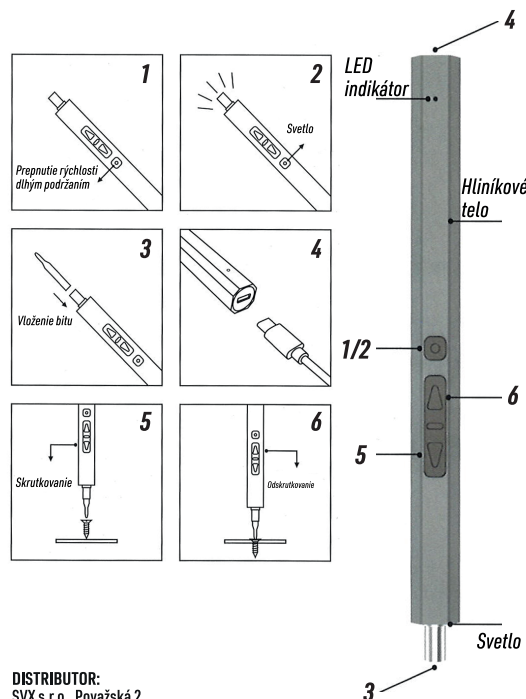

DISTRIBUTOR:
SVX s.r.o., Považská 2,
940 02 Nové Zámky, Slovakia
Made in PRC.

Parametry produktu

Rozměr: 16x16x180 mm
Váha: 71 g
Převod: 2 převody
Rychlost naprázdno: 200 ot/min
Krouticí moment: 0,3 Nm / 0,4 Nm

Napětí baterie : 3,7 V
Lithium-iontová baterie: 350 mAh
Doba nabíjení: 60 min
Pohotovostní režim: 60 dní
Pracovní doba: 120 min

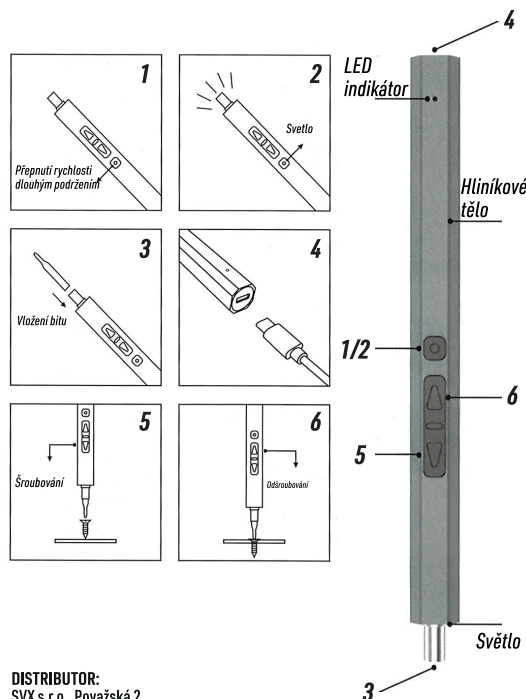

DISTRIBUTOR:
SVX s.r.o., Považská 2,
940 02 Nové Zámky, Slovakia
Made in PRC.

Termék paramétere

Méret: 16x16x180 mm
Súly: 71 g
Áttétel: 2 fokozat
Üresjárat sebesség: 200 ford/perc
Nyomaték: 0,3 Nm / 0,4 Nm

Akkufeszültség: 3,7 V
Lítium akkumulátor: 350 mAh
Töltési idő: 60 perc
Készenléti idő: 60 nap
Működési idő: 120 perc

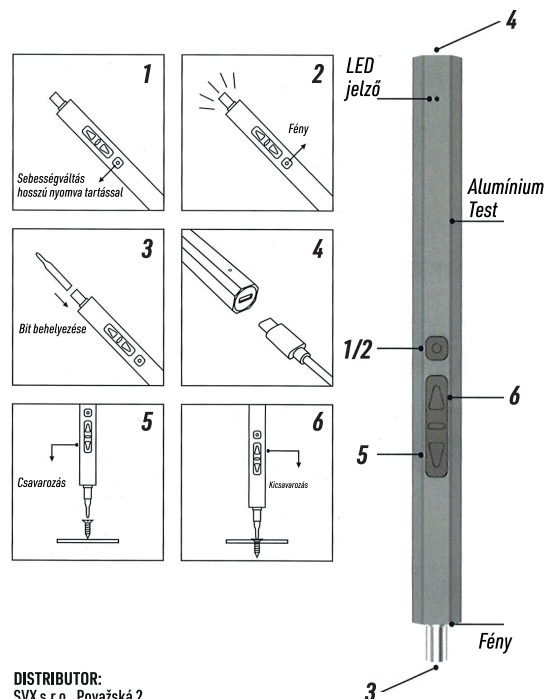

DISTRIBUTOR:
SVX s.r.o., Považská 2,
940 02 Nové Zámky, Slovakia
Made in PRC.

Product parameters

Dimensions: 16x16x180 mm
Weight: 71 g
Gear: 2 gears
No-load speed: 200 RPM
Torque: 0.3 Nm / 0.4 Nm

Battery voltage: 3.7 V
Lithium battery: 350 mAh
Charging time: 60 min
Standby time: 60 days
Working time: 120 min

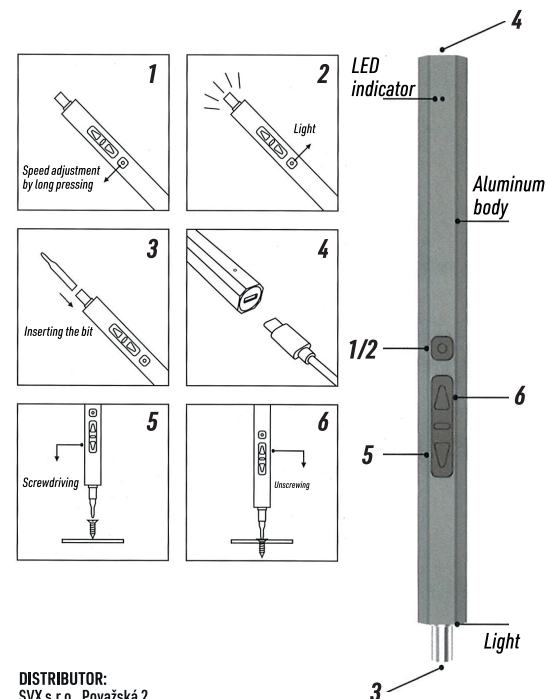

DISTRIBUTOR:
SVX s.r.o., Považská 2,
940 02 Nové Zámky, Slovakia
Made in PRC.